

## Optimization of Palm Oil Plantation Revitalization in North Sumatera Indonesia

Juliza Hidayati<sup>#</sup>, Sukardi<sup>\*</sup>, Ani Suryani<sup>\*</sup>, Anas Miftah Fauzi<sup>\*</sup> and Sugiharto<sup>1</sup>

<sup>#</sup> Department of Industrial Engineering, Faculty of Engineering, University of North Sumatra, Medan, Indonesia  
E-mail: rivaijuliza@gmail.com

<sup>\*</sup> Agricultural Industry Technology Department, Bogor Agricultural University, Bogor, Indonesia

<sup>1</sup> PT Pertamina (Persero), Jakarta 10110, Indonesia

---

**Abstract**— The idea of making North Sumatera as a barometer of national oil palm industry require efforts commodities and agro-industry development of oil palm. One effort that can be done is by successful execution plantation revitalization. The plantation Revitalization is an effort to accelerate the development of smallholder plantations, through expansion and replanting by help of palm estate company as business partner and bank financed plantation revitalization fund. Business partner agreement obliged and bound to make at least the same smallholder plantation productivity with business partners, so that the refund rate to banks become larger and prosperous people as a plantation owner. Generally low productivity of smallholder plantations under normal potential caused a lot of old and damaged plants with plant material at random. The purpose of revitalizing oil palm plantations which are to increase their competitiveness through increased farm productivity. The research aims to identify potential criteria in influencing plantation productivity improvement priorities to be observed and followed up in order to improve the competitiveness of destinations and make North Sumatera barometer of national palm oil can be achieved. Research conducted with Analytical Network Process (ANP), to find the effect of dependency relationships between factors or criteria with the knowledge of the experts in order to produce an objective opinion and relevant depict the actual situation.

**Keywords**— palm barometer; acceleration of plantation development; productivity; revitalization

---

### I. INTRODUCTION

The potential of natural resources in the region of North Sumatera Indonesia is very large with a spacious plantation reaches 15.2% of the Indonesian palm oil plantations, CPO exports amounted to 7.9% of the total Indonesian palm oil exports, and the composition of unproductive young plants are estimated around 17.2% of the total national palm oil plantations. To support the idea of making North Sumatera as a barometer of the national palm oil [15], it is needed to strengthen the availability of CPO agroindustry raw materials by maximizing the potential through the expansion and rejuvenation of plantation crops (plantation revitalization) to support the development of palm oil agroindustry in North Sumatera.

Plantation Revitalization is an effort to accelerate the development of smallholder plantation through the expansion, renovation and rehabilitation of the plantation crops which are supported by the banking and investment credit and also interest subsidy by the government involving palm estate companies as partners in the development and

processing and marketing of production. Development efforts of plantation commodities face various problems such as low crop productivity under normal potential, due to a lot of old and damaged plants with random plant materials. On the other hand, one of the program goals is to improve competitiveness through increased productivity and development of plantation-based downstream industries.

Low productivity and quality is a common problem of Indonesian palm oil estates. The amount of production highly depends on the type of soil, seed varieties, climate and technology applied. When compared to government palm oil estates and private palm oil estates then the soil conditions are relatively the same, but the results were much different in production. In optimal circumstances, the productivity of palm oil can reach 20-25 tonnes FFB / ha / year, or about 4-5 tonnes of CPO North Sumatera condition nowadays is still around 3.8 tonnes of CPO / ha / year, while its potential is about 7 tons of CPO / ha / year.

Integrated oil palm development from upstream to downstream in the industrial area Sei Mangkei targeted by 2015 the use of CPO in North Sumatra reached 5,250

thousand tons and increased again in number in 2020 became 6,200 thousand tons. As the world's largest CPO producer, with production in 2014 reached 29,3 million tons with a total area 10,9 million hectares [4], Indonesia requires balance and continuity of raw material palm FFB and CPO processing industry ranging from up to downstream industries such as cooking oil, soap, margarine, oleochemical and biofuel. There are at least 12 species of palm oil-derived products are planned to be produced from the industrial area Sei Mangke North Sumatra, including cooking oil, margarine, biodiesel, beta-carotene, fatty acid, fatty alcohol and surfactants.

Vegetable oil needs of the world that continues to increase in line with the rapid increase in demand of CPO consumer countries particularly China, India and the European Union [12] and along with the growth of world population expanding rapidly (from 7 billion in 2011 will become 9.5 billion in 2050 ) requires effort that is consistent from Indonesia to keep increasing production. Demand for palm oil increased driven by population growth and increase in gross domestic product [14], and also the additional demand for biodiesel [29]. The palm oil industry is an industry that is influenced by free market mechanisms [2] and the balance of supply and demand is the basis for the creation of price.

The problem is due to the undeveloped downstream palm oil industry, large CPO exports, low level of technology, management, and quality of human resources [13]. Today, CPO export has been decreased to 50% with the use of CPO for downstream industries to 50% [10].

The efforts to improve the productivity of palm oil estates can be done by using superior cultivation techniques, the actions of technical culture and environmental factors [21]. The management of environment to grow, especially the availability of water is relatively more difficult than technical culture techniques such as the use of superior plant materials, plant spacing, fertilization, pest and disease control and Treatment plant, so that environmental factors are a major limiting factor in the production of palm oil [21].

The potential for the development of palm oil in North Sumatra is supported by the resources available, so the idea to make North Sumatra as a barometer of national palm oil is not impossible to happen. One way to make it work is to implement the revitalization of palm oil estates. This revitalization includes the expansion and the rejuvenation of the estate with the aim of optimizing the productivity of estates and the CPO agroindustry. The efforts to optimize the productivity of palm oil estates in North Sumatra at this time can not only be directed at the expansion of the land, but the productivity per hectare crop yield. This is due to limited potential land for palm oil. The problem is how the efforts can be done to improve the productivity of palm oil estates and CPO agroindustry from which it should be produced with the great potential owned by North Sumatra, so that the production targets which are to support the needs of the downstream of CPO agroindustry and to strengthen it can be fulfilled in accordance with the greater market demand in the future.

The problem occur from the effort of revitalizing North Sumatra as the first region of North Sumatra in Indonesia, which produces palm oil so famous as the granary of the national palm oil. Currently, North Sumatra is targeted to

be a barometer of the national palm oil [9]. This is supported by the palm oil estate revitalization program that targets the improvement of the national palm oil productivity and qualified products in order to achieve the production targets in an effort to develop downstream industries and increase the added value. The problem faced in doing the revitalization palm oil estates is a FFB balance or continuity produced in estates to meet the abroad and domestic demands especially the needs of CPO agroindustry and downstream industry in North Sumatera.

This study aims at identifying the potential criteria that influence the determinant factors in the improvement of estate productivities and CPO agroindustry which are prioritized to be observed and followed up in order that the goal of increasing competitiveness and making North Sumatra as the barometer of national palm oil can be achieved.

## II. METHODS

### A. Framework

Analytical Network Process provides a general framework in treating decisions without making assumptions about the independence of the elements at a higher level than the elements at a lower level and on the independence of the elements in a level [23]. Network spread in all directions and allows the influence of a cluster to another cluster and the cluster itself and form a reciprocal cycle [23].

### B. Procedures

The study was conducted in palm estate companies and CPO agroindustry in North Sumatra Indonesia. Primary data were obtained through direct observation in the field and interviews with experts in accordance with the research topic, the questionnaire tool. The collection of primary data through questionnaires or interviews were conducted using a purposive sampling technique, based on the the researcher assessment of the resource persons who meet the requirements as seen from the knowledge background or experience in order to achieve some results in line with the research objectives.

System increased productivity plantations and agroindustry CPO needs primary data for factors conformity land, quality of seeds, plant population per hectare and crop uniformity, fertilizing, treatment plants, method of work, application of technology, skill labor for plants and agroindustry CPO, supervision, quality of fresh fruit bunch (FFB), and factor process technology.

Field observations performed at several large estates, CPO agroindustry in North Sumatra, local and central government which are involved in plantation revitalization program. The collection of information from several experts conducted structurally by using the tools of questionnaire and unstructurally by conducting interviews. Resource persons came from the estate practitioners and the CPO agroindustry practitioners, researchers of Indonesian Oil Palm Research Institute (IOPRI), and special estate agencies of Horticulture Plantation Revitalization Department. The secondary data were obtained from literature, Central Bureau of Statistics, North Sumatra Plantation Office, Directorate General of Estates, Regional Development Planning Agency

of North Sumatera, PTPN III dan IV which have CPO agroindustry and GAPKI.

The study examines the palm estate companies as a partner in the plantation development, processing and marketing of results and the CPO agroindustry by making the decision model of multi-criteria decision making that uses the criteria of productivity in the estate. It began with identifying and assessing the variables involved in improving the productivity of palm oil estates and the CPO agroindustry. After all were identified, distributing questionnaires of pairwise comparisons were conducted on expert judgments to determine their preferences. The scale used is the scale that starts from the same limited importance (Equally preferred) to the absolute importance (extremely preferred). Scale selection of 1 to 9 is based on psychological research that is based on the ability of the human brain in expressing his order of preference. Expected given assessment is hoped to be based on expert assessment. Productivity improvement process flow diagram is presented in Figure 1.

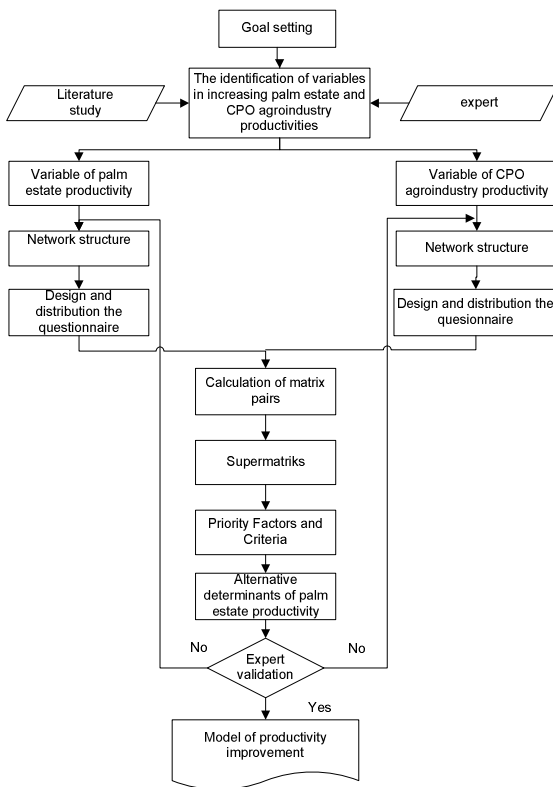

Fig. 1 Flow diagram of estate productivity improvement process

This decision model uses network analysis process required to reach the goals which have been set. Rationale estate and CPO agroindustry productivity is important to evaluate, because the company will be implementing the revitalization of estate, with the rejuvenation and expansion of palm oil estate. Thus started from nurseries / seed selection, planting, maintenance, harvesting up to marketing of the products become the responsibility of the estate company. When there is an obligation by the palm estate company to be a guarantee of investment credit disbursed by banks will lead a palm estate company to be fully bound to make the palm oil estates managed to produce the results in

accordance with the target productivity levels equal to that of the main estate and keep the quality of the estate in accordance with the technical standards so that assured certainty and sustainability efforts are guaranteed (according to the instructions of technical standards determined by the Minister of Agriculture cq. Directorate General of Estates).

### III. RESULT AND DISCUSSION

Plantation Revitalization is an effort to accelerate the development of plantation through the expansion, rejuvenation and rehabilitation of plantations which is supported by the banking investment credit and interest subsidy by the government involving palm estate company in the business as a partner in improving the development of plantation, processing and product marketing [3]. This definition covers several important aspects, including the aspects of the development of smallholders, and aspects of the company as a plantation developing partner, processing and marketing results.

Factors that increase estate productivity refer to the environmental aspects, aspects of human resources and aspects of plant materials [14]; environmental factors, factors of plant material and agronomic measures factor [22]. Environmental factors (land) is an important factor because the palm oil plant will not grow economically if it is not planted on suitable land, so these factors are described with land suitability. Human resource factors are also important considerations based on plantation agriculture which is a business unit with a large-scale organization of labor intensive with detailed division of labor, modern technology, specialization, and system administration. These factors are described in the skill labor (specialization), supervision (system administration) and technology (working methods and the application of technology). Plant material factor is important because the selection of inappropriate plant material will bring a very big risk and will cause the company a loss of funds, time and effort if the seeds planted were not in accordance with the expected results. These factors are described in the quality of the seed. The technical culture factors most affect the growth and productivity, among others: seeding, fertilizing, plant population per acre and crop uniformity, and Treatment plant.

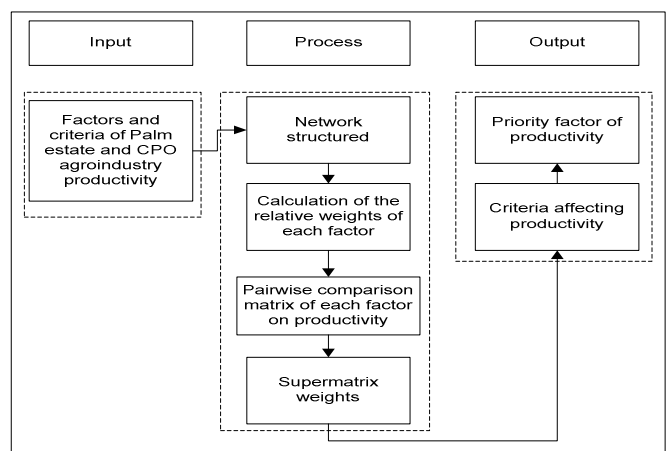

Fig. 2 Diagram of input-output models improvement palm estate and CPO agroindustry productivity

The productivity of the plant is the plant's ability to process raw materials or inputs in the form of fresh fruit bunches (FFB) to get a result at least as compared with an input capacity of fresh fruit bunches. The ability of palm oil mills seen from the production of CPO per hectare and the quality of palm oil produced. It is obtained by minimizing loss (losses) palm oil. Diagram of input output model of productivity improvement is illustrated in Figure 2.

The network structure of estate productivity is based on the theories of palm oil production and the efforts that can be done to increase the production of palm oil, with the involvement of resource persons who have expertise to understand and indeed involved (practitioners) in plantation and CPO agroindustry activities to get an accurate assessment and were able to describe the actual conditions of the factors and criteria whose weight will be identified and determined in the analysis of *Analytical Network Process*. Analysis using ANP estimates the reciprocal relationship or dependence (feedback) from each level from top to bottom and vice versa in the structure of the network, so there is no a hierarchy in which the assessment is only done from the top down and the bottom level does not affect the levels upon it.

The estate productivity network structure is depicted in Figure 3, and CPO agroindustry in Figure 4. Dependency relationships between clusters or factors and the relationship between the criteria in the cluster are indicated by arrows. Curved arrows above each cluster show the interplay within the cluster or factor itself, while the arrows coming out of the cluster show the relationship between affect or influence each other inter different criteria cluster. Factors of land suitability interplay with factors of technology applications, fertilization and Treatment plant. As well as criteria harvest technologies affecting the transport criteria in the quality of fresh fruit bunches cluster. While the seed quality factors, SPH and homogeneity (population per hectare and crop uniformity) and working methods are influenced by factors of land suitability. The relationship clusters quality fresh fruit bunches affect process technology clusters, where the level of ripeness affects the type of technology, the tools condition criteria and procedures in the process of technology clusters. While in the process of technology clusters and clusters of skill labor is found there is a relationship of mutual influence and reciprocal, criteria for the tools condition affecting labor skills from experience and from education.

The final results of the ANP is limited supermatrix which is a multiplication of supermatriks with himself. This limited Supermatrix provides a constant weight value of several iterations multiplication supermatriks happened. Limited Supermatrix produces a constant weight value of each criterion based on the analysis of the feedback from each of the criteria to other criteria, either in the same cluster or factor or not.

Reciprocal relationships (feedback) and mutual influence among the criteria in one cluster or inter-cluster criteria to improve the productivity of palm oil estates by using ANP generate priority criteria. The priority criteria of increasing estate productivity is shown in Table 1 below. ANP results indicate that the population factor and uniformity of plants per hectare (Stand Per hectares and homogeneity), treatment

plants, fertilizing, working methods, land suitability and application of technology become the determining factors in improving the productivity of palm oil estates. For more details, the results of the ANP for each criterion in the cluster and inter-cluster criteria that shows the interrelationships and mutual influences can be seen in Figure 5. Clusters and criteria described are the cluster and the criteria that have limited weights on supermatrix shown in Table 1, so that only clusters and criteria with the weights above zero are described to have connectedness and reciprocal interplay in improving the productivity of palm oil estates.

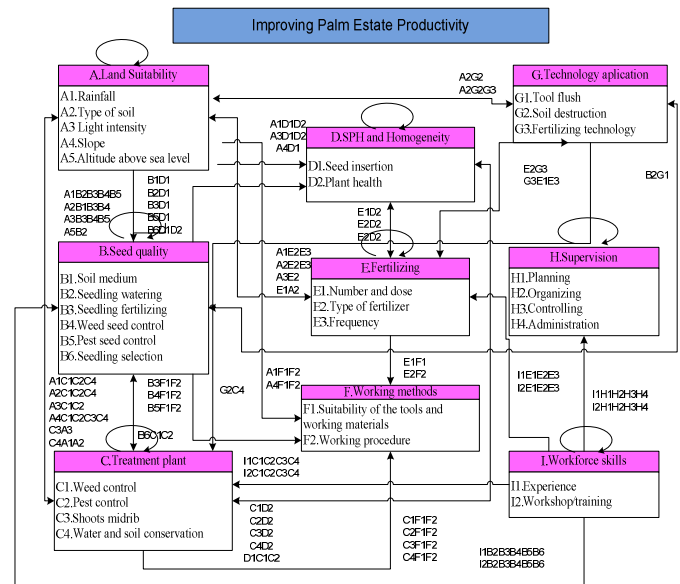

Fig. 3 The network structure of palm estate productivity

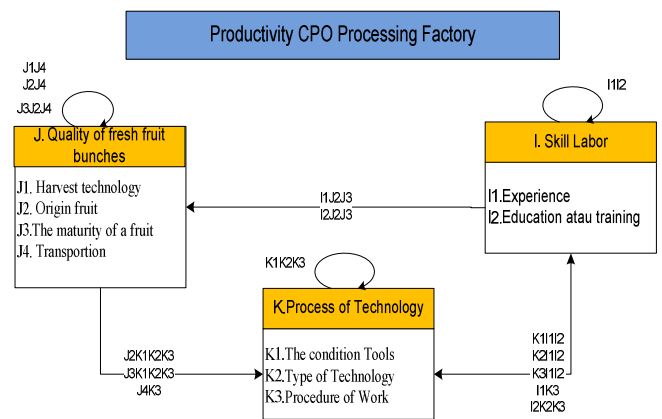

Fig 4 The network structures of CPO agroindustry productivity

In the cluster of plant population per hectare and uniformity of plants, plant health and seed insertion interplay (no reciprocal links) to the cluster fertilizers, treatment plant, and technology applications. But the land suitability cluster only gives effect to the insertion of seeds and plant health. Interactions also occur among the criteria in the cluster population per acre and crop uniformity.

TABLE I  
PRIORITY CRITERIA FOR INCREASED PALM ESTATE PRODUCTIVITY

	Criteria	Weight
A1	Rainfall	0,00522
A2	Type of soil	0,05703
A3	Light intensity	0
A4	Slope	0
A5	Altitude above sea	0
B1	Soil medium	0,01609
B2	Watering seedlings	0,0282
B3	Fertilizing seedlings	0,00247
B4	Pest control seedlings	0,00389
B5	Weed seed	0,00808
B6	Seed selection	0,01335
C1	Weed control	0,04167
C2	Pest control	0,03783
C3	Shoots midrib	0
C4	Water and soil conservation	0,02201
D1	Seed insertion	0,13056
D2	Plant health	0,18459
E1	Amount and dose of fertilizer	0,1023
E2	Fertilizer type	0,11675
E3	Fertilizer frequency	0,05709
F1	The suitability of the tool and the work material	0,07209
F2	Work procedure	0,04856
G1	Tool flush	0,00306
G2	Destruction of soil	0,01333
G3	Fertilizing technology	0,03595

TABLE II  
PRIORITY CRITERIA FOR INCREASED CPO AGROINDUSTRY PRODUCTIVITY

	Criteria	Weight
J1	Harvest Teknologi	0
J2	The source of Fruit	0,03089
J3	The maturity of a fruit	0,13028
J4	Transportion	0,06806
K1	The condition of instrument	0,01169
K2	Jenis teknologi	0,04346
K3	Procedure of work	0,26971
I1	Experience	0,1725
I2	Education / Training	0,27342

A. The factors increasing palm oil plantations productivity

1) Population factors per acre and crop uniformity (SPH and homogeneity) is a major factor in improving the productivity of palm oil estates. This factor consists of plant health and the insertion of seeds. This is supported by Purba [19] which states that the limiting factor to achieve high productivity of palm oil estates in North Sumatera is heterogeneity, due to high insertion plants. Prihutami also states the plant population per hectare becomes the determinants of the increase in palm oil production while rainfall will have no effect on the increase in palm oil production due to the high diversity of the population because of the high heterogeneity planting year [16].

The weights of plant health and the insertion are big, because most activities conducted in palm oil plantations will affect the insertion and the health of these plants. The insertion of the plant is an activity that is being conducted at the time of planting seedlings to estates with the aim of getting a fixed amount of crops and the low variation from different planting year. In terms of number, seed insertion is done to get the number optimization of trees per hectare. Meanwhile in terms of years of planting, it is to suppress heterogeneity, for easy set up and give the same treatment in fertilization, weed and pest control. This insertion is more

affecting than the weed control pest and disease control. Principally, if the weed is clean, then it will reduce pests. So the plants will get light intensity which is relatively the same and this can improve plant health. Plant health includes the adequacy and balance of nutrients and plant resistance to pests and diseases.

Superior quality seeds will be useless if it is not done in the insertion activity fields. Seedling pest control, fertilizing and watering seeds are activities that will directly affect the insertion of the plant. This applies also to the health criteria that determines the homogeneous plant crops in fields. Plant populations per hectare and homogeneity of these plants become the main factors to consider if the efforts to increase the productivities are done.

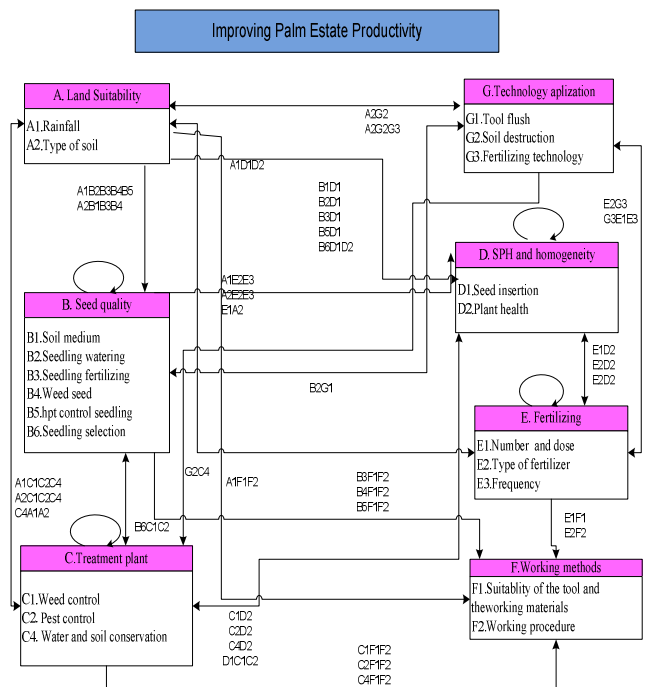

Fig. 5 Interplay productivity improvement of palm oil estate

2) Fertilizing Factor consists of fertilizer, the amount or dose of fertilizer and frequency. This factor has a high weight and determines the increase in farm productivity, which means fertilization is absolutely necessary if the production of palm oil per hectare of crop needs to be improved.

Fertilization is necessary to restore the land's ability to provide nutrients for the growth and development of palm oil estate, by improving soil fertility and increasing plant resistance to disease and unfavorable climatic influences. This is supported by Purwantoro which states that estate productivity differences are due to maintenance of the garden that is not the same, one of them is in terms of the provision of agro inputs [20]. Purba states that the constraints in increasing the productivity of palm oil estates is imperfect fertilization [19]. Fertilizer type and amount of fertilizer give significant effects to an increase in farm productivity [28].

3) Working method factor consists of criteria of tools and working materials suitability and the working procedure criteria. Risza stated that efforts directed at the determination and application of the most suitable working methods have a

major impact on productivity [22]. Hence, working procedure needs to be applied. For pest control activities, the work procedures are more influencing than the suitability of the tool and the work material. It is in contrast to the activity or weed control criteria, because it affects the suitability of the tool and the work material rather than working procedures. Working methods affect the quality of seeds, fertilizers and Treatment plant, while all three of these factors greatly affect plant health and seed insertion which are the main criteria in increasing productivity of palm oil estates.

4) Plant treatment factor consists of soil and water conservation, pest and disease control, weed control and midrib stemming. Weed control, pest control and the conservation of soil and water have a high weight and large enough impact to improve the productivity of estates. Control of weeds / pests and diseases is an attempt to protect / care for plants. Weed control is an attempt to increase the competitiveness of palm trees and undermine the competitiveness of weeds, to control plant life with the understanding concept of the life cycle of pests / diseases [14]. Understanding knowledge about weakest part of the life cycle of the chain is very useful in controlling plant pests and diseases effectively. Purba stated that the limiting factor of achieving crop productivities is the stemming delay and weed control [19], and Tarmisor states that the amount of pesticides used in pest and disease control is the factor that affects the productivity of estates [28].

5) Seedling quality factor is dominated by criteria of fertilizing seeds, the use of soil media, seed selection, watering seedlings, pest and disease control seedlings and weed control. Purwantoro states that the constraints to increase the productivity of palm oil estates are that the seeds used must be original [20]. Purba stated that the key in improving productivity is superior plant materials and seed types [19]. To get quality seeds and high productivity per hectare of land, the activities of selecting seeds and watering the seedlings should be prioritized and done properly. Selection of seedlings describes the condition of seedlings which are ready to plant (seeds that have been selected). This seed selection is a the combination of how the work of watering, fertilizing, the control of weed and seedling pests, and how the use of soil media is done. This is a result reflecting of all activities in producing quality seedlings in the nursery. Watering the seeds is usually done in the lowlands, so water availability is not a problem. Seed selection activity is done continuously. Seedling pest control, fertilizing and watering seeds are activities that directly affect the insertion of the plant. The quality factor of these seeds can be organized and managed as needed.

6) Land suitability factor is is dominated by the criteria of soil type and rainfall. This factor weights relatively small because land suitability criteria such as rainfall, slope and altitude from sea level can not be adjusted as needed. Agustira and Amelia stated that the land suitability which is imposed leads to low productivity of palm oil estates [1]. In line with Purba who stated the suitability of land affects to the increase of crop productivity [19]. Soil type has the highest weight because it can be affected by soil conservation and types of fertilizers applied to crops. The type of soil meant is the soil physical properties which are

usually distinguished between peat or mineral soil, and the hardpan or non hardpan soil. This is supported by Tarigan and Sipayung who stated the increase of plantation productivity can be done through biological and physical soil improvements [27]. Likewise, the rainfall can only be influenced or adjusted to the needs of soil and water conservation. Generally altitude affects rainfall. According to Siregar the rainfall is a climate suitability parameter to improve the productivity of palm oil estates [26]. But the criteria of light intensity, slope and land elevation from sea level are not adjustable and can not be customized as needed. In general, Goenadi stated the productivity of plants in the field is determined by the variety in its interaction with climate and soil fertility and pest nuisance [5].

7) Technology application factor, described in the use of technology or tool flush of watering seedlings, soil destruction technology and fertilization technology. Yahya said that cultivation technology is required at all stages in an effort to improve crop productivity [28]. Tarigan and Sipayung suggested to increase palm estate productivity by using technology and site-specific management plantation [27]. Increasing productivity by utilizing technology and innovation to increase production of CPO per hectare of land will produce more from less land area [6].

Each of the criteria for the application of the technology factor in increasing the productivity of estates has influences and affects a large enough with weight fertilization technology around, soil destruction technology, and flush or technological tool watering seedlings. Fertilization affects seed fertilizer technology, the amount and dose of fertilizer, and the frequency of fertilization. Technology application of land destruction affects and is affected by soil type, soil media seeding, and soil and water conservation in improving farm productivity. Meanwhile, watering technology application affects the seedling watering.

8) Supervision factor consists of criteria of planning, organizing, supervision and administration. Supervision is closely related to workforce skills, not only in supervision, planning, or organization but also in administration of labor skills which is derived from training or experience in the training and employment.

9) Workforce skill factor consists of the criteria of experience and education or training. To improve the productivity of estates, training for employment needs to be encouraged and the implementation should be controlled. This is because the estates are generally labor intensive, where labor is generally down high school education, only a few educated scholars with expertise. Accommodative factor of palm oil estates in the workforce who have no formal skills (high school and under) is related to the technological characteristics of palm oil estates with labor intensive to solid expertise / skills [27]. The low level of education at these locations will result in the low adoption and motivation of estate smallholders to manage the plantation [25]. Workforce skill factor and supervision have a weight close to zero, so it does not give any influence to the efforts to increase the productivity of palm oil estates.

10) Skill labor factor influenced two criteria in improving the productivity of agro-industry, with first rank criteria of education or training and the second is experience. Education or training the workforce is crucial in determining



the increase in productivity of the plant. Education or training labor force includes the introduction of tools, maintenance tools and machines, and operating equipment and machinery. So without the proper education and training will cause stunted technical plant operations, which will lead to low productivity of the plant.

11) Factor process technology influenced the three criteria, namely the working procedures, technology type and condition of the tool. Working procedures as a rule in the implementation of the processing in the plant has an enormous influence on the increase in plant productivity. Technological technical efficiency is defined as the effectiveness and productivity in the operation of the plant. A plant is less efficient when the amount of losses, quality output and palm kernel oil extraction and production capacity are not in accordance with standard norms. It can be seen from a capacity that is not in accordance with the design capacity, high losses and poor quality [14]. Working procedure is the rule in the application of the technology used for the processing of palm oil. The condition of the tool is meant is the state of the tool in the processing of palm oil, whether new or old tool condition, and often broken or rarely. While this type of technology is the choice of equipment or machine used in the processing of palm oil.

12) Quality fresh fruit bunches factor influenced the three criteria, namely the level of ripe fruit, transportation, and the source of the fruit. The quality factor of fresh fruit bunches is not a dominant factor, because the productivity of the plant is the plant's ability to process raw materials or inputs of fresh fruit bunches (FFB) to get a result at least as compared with an input capacity of fresh fruit bunches. That is the quality of fresh fruit bunches as input already has the optimal oil percentage. So if the processing is done in the factory will not produce a greater percentage of oil than when the initial conditions of fresh fruit bunches into the factory.

The maturity of a fruit relating to rendement of CPO, at the maturity of a fruit certain will produce rendement and quality of certain. If the level maturity of a fruit low so procedure to fruit in the process different, contributed to productivity plant also would be different. The effectiveness and efficiency of oil palm processing influenced the level of maturity of fruit that can be known through a sort of fruit before it is processed. Fulfillment of the requirements of fruit maturity will give good quality results with low loss levels. Fruit maturity level indicates the percentage of the condition of the raw fruit, unripe or ripe harvested. Differences with the maturity level of the harvest, which means the fruit is not harvested, to estimate how much fruit that can be harvested per unit area in ripe condition. Criteria harvesting technology does not affect the quality of fresh fruit bunches in increasing the productivity of CPO processing plants. Harvest technology is a tool or a way to harvest by machine (or mechanization tools) that can speed up the process of harvesting so that high output and damage to fruit at harvest was reduced (affecting the quality of the fruit).

Criteria source of fruit or origin fruit, are the condition of the fruit was in common differentiated in of sorting of fresh fruit bunch palm oil derived from the smallholder plantation usually having the quality of being lower than FFB of the

private plantation companies or the government. Transporting slow work will require different handling procedures. The condition of the road infrastructure as a means of transportation of oil production greatly influence the transportation of crops. The long distance between the farm and factory pose a risk of delays in transporting the crop, can reach one week to be transported. Delays in processing time will reduce the rendement and quality of the CPO because most of its oil to be turned into free fatty acids (FFA).

**B. Palm oil estates productivity**

The aim at improving the productivity of palm oil estates will be successful if the criteria for plant health and seed insertion are conducted continuously and become a top priority for a success in productivity increase. Plant health can only be generated from the treatment to produce quality seeds, fertilizers and proper Treatment plant. While the factors of working methods, the suitability criteria of tool and working materials, and working procedures become the factors for supporting the implementation of fertilization, crop care and breeding activity (to get quality seeds). Factors of quality seeds, fertilizers, Treatment plant, and other factors supporting the increase of productivity (work methods, application of technology, labor skills, and supervision) become the factors that can be controlled or regulated and can be adjusted to the needs.

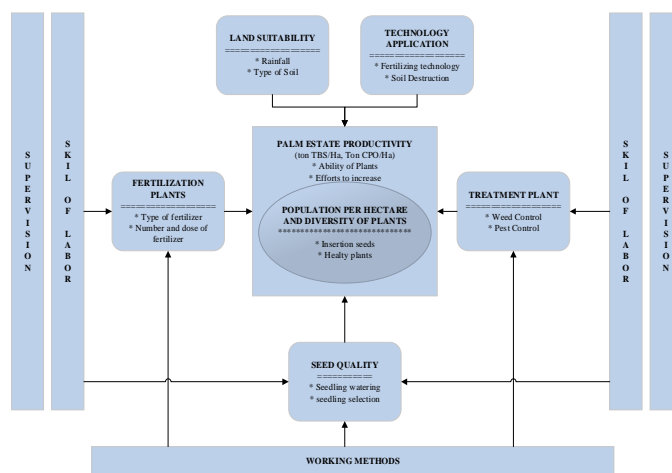

Fig. 6 Correlations among the factors in increasing the productivity of palm oil plantation

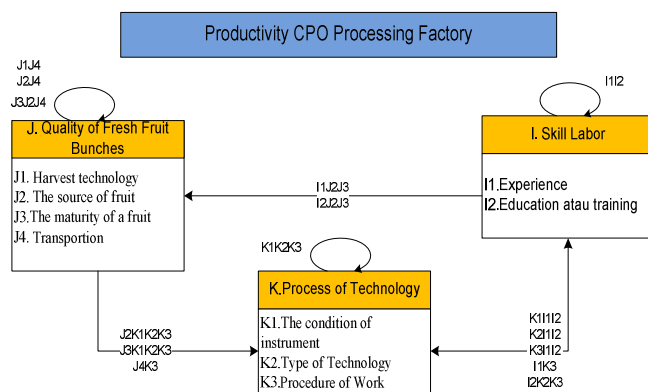

Fig. 7 Interplay Productivity Improvement of CPO Agroindustry

### C. CPO agroindustry productivity

The aim of increasing the productivity of palm oil mill will be successful if the process technology and education or training to the workforce a priority to be implemented. Criteria working procedures becomes the criterion that was instrumental in the technological processing of Palm oil, followed by fruit maturity level in providing quality higher fresh fruit bunches as input palm oil mills. Process technology will be effective if supported by appropriate labor skills, which will lead to increased productivity in the palm oil mills. Or work procedures would be maximized if the education and experience of factory work force in accordance with the specification should have been required in the processing of Palm oil. The productivity of the plant is the process technology capabilities including workforce skills to maximize the processing and harvesting of input capacity quality fresh fruit bunches (FFB). The result of ANP show the criteria and the factors increasing productivity a factory that produces palm oil based on the mutual relations and dependence is illustrated in Fig 8.

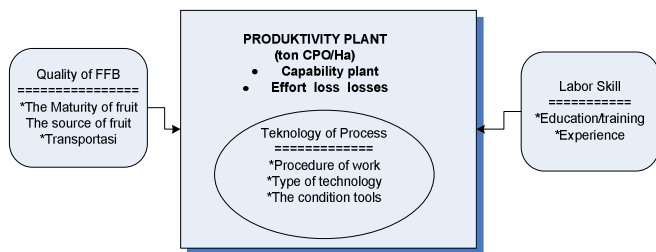

Fig 8. Relation of Productivity Factor CPO Processing Plant

The results of this study are verified to get a match between the input and output of the model whether or not it is running correctly. If there are some errors, then the model should be improved. The model of increasing productivity of palm oil estates and palm oil mills are built using Analytic Network Process, which is Super Decision ANP tools version 2.0.8. ANP method using Super Decision already has its own verification by calculating the inconsistency of the expert answers to the questionnaires which are presented in a pairwise comparison matrix. ANP processing results for each expert are processed to obtain the geometric mean of the experts. The results of the geometric mean is inserted into the input on the pairwise comparison matrix in ANP for a combination of all experts. ANP processing results in the form of a limited supermatrix are the weights for each criterion and cluster. From this supermatrix, priority of each criterion and inconsistency resulted from all reciprocal relationship among clusters and the criteria can be generated. There is ANP inconsistency result below 0.1 which indicates that the model has an acceptable consistency.

Furthermore, the model is validated to obtain valid models using the technique of face validity [24]. Questions are submitted to the experts who have the capability in palm oil estates and the CPO agroindustry. These experts are from the plantation practitioners, CPO agroindustry practitioners, RPN researchers, the Head of estate revitalization (Departement of Estate in North Sumatera). The technical implementation process is by presenting the model used in

the research, experts then are given questionnaires to assess the model.

### IV. CONCLUSIONS

The Priority criteria have greatest impact to increase palm estate productivity is crop health, insertion of seeds, the type of fertilizer, the amount and dose of fertilizer, the suitability of the tool and the working materials, the type of soil, the frequency of fertilizer, work procedures, weed control, pest control, fertilization technology, and the fertilization of seeds. While for productivity of CPO agroindustry is education or training, the working procedure, experience, fruit maturity level, and a source of fruit.

The priority factors to increasing the productivity of palm oil estates is a population of plants per hectare and uniformity of plants, fertilizing, work methods, Treatment plant, seed quality, land suitability and application of technology. While for CPO agroindustry is labor skills, technological processes and quality of fresh fruit bunches.

Plant populations per hectare & homogeneity of plants (31.5%) and skill for factory labor (44.59%) are the major factors to be observed and followed to increase the productivity of palm oil plantation.

### REFERENCES

- [1] Agustira, M.A., Amelia, R. (2012). Kendala peningkatan produktivitas pada perkebunan kelapa sawit rakyat di Indonesia. *Warta PPKS* 17(1):21-29.
- [2] Chalil D. (2008). Market Power and Subsidies in Indonesian palm Oil Industry. Canberra: AARES 52nd Annual Conference.
- [3] Direktorat Jenderal Perkebunan (2010). Pedoman Umum Program Revitalisasi Perkebunan (Kelapa Sawit, Karet dan kakao, Edisi revisi. Direktorat Jenderal Perkebunan. Departemen Pertanian, Jakarta.
- [4] Direktorat Jenderal Perkebunan (2014). Statistik Komoditas Kelapa Sawit. Direktorat Jenderal Perkebunan. Departemen Pertanian, Jakarta.
- [5] Goenadi, D.H. (2007). Revitalisasi Perkebunan Sudahkan di Jalan yang Benar. 2007. <http://www.litbang.deptan.go.id>. [23 Juli 2012]
- [6] Golden Agri Resouces Ltd. 2011. Laporan Keberlanjutan 2011: Melestarikan Masa Kini, Menjamin Masa Depan.
- [7] Gumbira, S.E. (2001). Penerapan Manajemen Teknologi dalam Meningkatkan Daya Saing Global Produk Agrobisnis/ Agroindustri Berorientasi Produk Berkelanjutan. Orasi Guru Besar Teknologi Industri Pertanian. 17 Maret 2001. Institut Pertanian Bogor. Bogor.
- [8] Hakim, M. (2007). Kelapa Sawit, Teknis Agronomis dan Manajemennya (Tinjauan Teoritis dan Praktis), Buku Pegangan Agronomis dan Pengusaha Kelapa Sawit, Lembaga Pupuk Indonesia. Jakarta.
- [9] Kartika A. 2010. Sumatera Utara sebagai Barometer Industri Perkebunan Berbasis Kelapa Sawit. *Jurnal Keuangan dan Bisnis*. Vol.2(1):1-7.
- [10] Kementerian Perindustrian Republik Indonesia (2014). Bila Aturan Ekspor Masih Lemah. 2014. <http://www.kemenprin.go.id/artikel>. [28 Juni 2014]
- [11] Masyarakat Kelapa Sawit Indonesia (2010). Penguatan Potensi dan Nilai Tambah Industri Kelapa Sawit Nasional, Menghadapi Isu Global dan Daya Saing Internasional, Institut Pertanian Bogor.
- [12] Miranti, E. (2010). Prospek pengembangan kelapa sawit 2010. *Economic Review* 219:1-12.
- [13] Nasution, H. (2012). Potensi dan Inovasi Pengembangan Kelapa Sawit dan Karet dalam Rangka Optimalisasi Nilai Tambah. Executive Summary. Universitas Sumatera Utara.
- [14] Pahan, I. (2010). Panduan Lengkap Kelapa Sawit: Manajemen Agribisnis dari Hulu hingga Hilir, Penebar Swadaya. Jakarta.
- [15] Pakpahan, A. (2011). North Sumatera Palm Oil Valley: Solusi Industri dan Perdagangan Berbasis Kelapa Sawit Abad ke 21, Suara Pambaruan.
- [16] Prihutami, N.D. (2011). Analisis Faktor Penentu Produksi Tandan Buah Segar (TBS) Tanaman Kelapa Sawit (*Elaeis Guineensis* Jacq.)



- di Sungai Bahaur Estate (SBHE), PT Bumitama Gunajaya Agro (PT BGA), Wilayah VI Metro Cempaga, Kotawaringin Timur, Kalimantan Tengah, Skripsi. Institut Pertanian Bogor. Bogor.
- [17] PT Bank Rakyat Indonesia (Persero). (2010). Kredit Pengembangan Energi Nabati dan Revitalisasi Perkebunan. Direktorat Jenderal Perkebunan. Jakarta.
- [18] PT Perkebunan Nusantara IV (2009). Sumut Jadi Barometer Industri Sawit Nasional, 2009. <http://www.ptpn4.co.id>. [25 Januari 2011]
- [19] Purba, A.R., Suprianto, E., Supena, N., dan Arif, M. (2009). Peningkatan produktivitas kelapa sawit dengan menggunakan bahan tanaman unggul. Prosiding Pertemuan Teknis Kelapa Sawit. Peningkatan Produktivitas Kelapa Sawit Menuju Sustainable Palm Oil. Pusat Penelitian Kelapa Sawit. Medan.
- [20] Purwanto RN. (2008). Sekilas pandang industri sawit., *Majalah Manajemen Usahawan Indonesia* LM FEUI 04:1-18.
- [21] Pusat Penelitian Kelapa Sawit. (2013). Bunga, buah dan produksi kelapa sawit. *Seri Kelapa Sawit Populer* 13. Medan.
- [22] Risza S. 2010. Masa Depan Perkebunan Kelapa Sawit Indonesia. Kanisius. Yogyakarta.
- [23] Saaty, T.L. 2004. Decision Making – The Analytic Hierarchy and Network Processes (AHP/ANP). *Journal of Systems Science and Systems Engineering*. Vol.13(1):ppl-34.
- [24] Sargent RG. 2010. Validation and Verification of Simulation Models. Di dalam *Proceedings of the 2010 Winter Simulation Conference*. Syracuse, NY 13244. USA
- [25] Sinaga, D.M., dan Hendarto, M. (2012). Analisis Kebijakan Pengelolaan Perkebunan Kelapa Sawit di Propinsi Sumatera Utara. *Diponegoro Journal of Economics* 1(2):1-13.
- [26] Siregar HH. 2004. Pendekatan Proses Hirarki Analitik untuk Penilaian Kesesuaian Iklim Perkebunan Kelapa Sawit. *Jurnal Penelitian Kelapa Sawit*. Vol.12(3):133-142.
- [27] Tarigan, B., dan Sipayung, T. (2011). Perkebunan Kelapa Sawit dalam Perekonomian Lingkungan Hidup Sumatera Utara, Gabungan Pengusaha Kelapa Sawit Indonesia cabang Sumatera Utara. IPB Press. Bogor.
- [28] Tarmisor. (2012). Efisiensi Produksi dan Umur Ekonomis Usahatani Kelapa Sawit di Kalimantan Timur, Disertasi. Pasca Sarjana, Universitas Gajah Mada, Yogyakarta.
- [29] Widjaja F. and Miang CK. (2008). *Agricultural Products*. CPO Industry fundamental infacts; Still attractive. Singapore: Morgan Stanley Research. Asia Pacific. Morgan Stanley Asia Pte.
- [30] Yahya, S., Herodian, S., dan Sasli, I. (2005). Pemanfaatan sumberdaya alami dalam peningkatan pertumbuhan tanaman perkebunan di lahan marginal. Makalah disampaikan pada Seminar Nasional Perkebunan Kelapa Sawit Rakyat. Pekanbaru.
- [31] Yunita, A.S. (2010). Analisis Faktor Penyebab Penurunan Produktivitas Kelapa Sawit (*Elaeis guineensis* Jacq.) di Kebun Sei Lala, PT Tunggul Perkasa Plantations. Indragiri Hulu, Riau, Skripsi. Institut Pertanian Bogor. Bogor.